



LUDIC-WHEEL - REALITY ENGINE DEVICE - OBJÉT CELIBATAIRE - PLAYING DADA-FUNK

FEATURES

- 3-axis XYZ micromachined acceleration
- Wireless Communication @ 9600Baud
- Designed in an emotional *ouvroir* (=space for contingency in *pataphysics*)
- Grey-Scale Encoding
- *Pataphysical* Circuitry
- 8Mhz Cycle Clock Speed
- *Objet de jeu, de vie et d'art*
- 3,3Volt Max887 Voltage Regulator
- Triggered happy and friendly fired out of the ludic society gamebased search artifacts of "GoApe-Chindogus"
- Self-constructed ball bearing containing 140 niro-steel balls
- Featuring Atmega8 Microcontroller
- *Jeu le CPU* and re-enact the designed glitch!
- *Nouvelles machines célibataires*
- For keeping balance but at the same time causing vertigo feelings
- The play on-stage as band is a play in the living machine

APPLICATION

- Neo-*Pataphysical* Game Interface
- Techno-Surrealist Sound Instrument
- Fashionable Style Accessoire

DESCRIPTION



Picture 1.0
objét celibataire 009-070307-b

The Ludic Society Monowheel is a proposal for a toy object. It refers to the *pataphysical* tradition of absurde instruments, is useless but also a working technological tool, a beautiful expressive circuit board, which serves as live performance instrument in the Reality Game Engine.

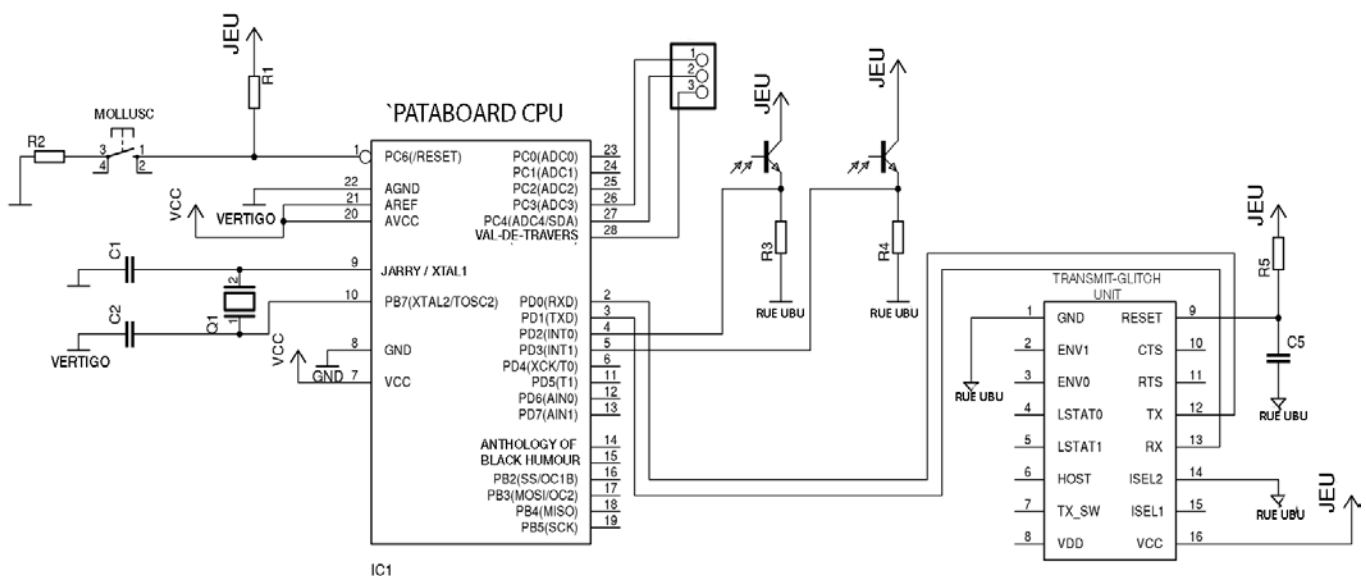

Picture 1.1
Block Diagramm



LUDIC-WHEEL - REALITY ENGINE DEVICE - OBJÉT CELIBATAIRE - PLAYING DADA-FUNK

As Street Play én Rue Pere Ubu

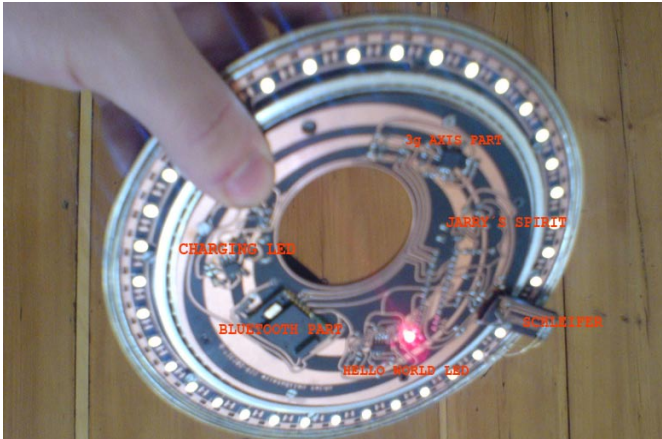

Picture 1.2
Parts Overview

The play (=on stage as band) is a play in the living machine. Cul-de-sac, the dead end street can be exited by destroying laptop-music, as neo-luddite in an lud/dic act, by literally smashing the laptop instead of the guitar as stage performance.

The live demonstration of rolling the potentiometer soldered with hot air on the self-etched circuit board allegorises the ride on the monowheel. It unhinges the player as well as the engine by strapping down a 3-axis accelerometer for keeping balance at the same time causing vertigo feelings for both; the passionate cyclist and the hardcore gamer.

The stage tool is still a chindogu (useless object), but starts to work more célibataire, acts more self-sufficient, rotates like a millwheel for music and makes the socialite even more attractive when playing with it.

These are objets célibataires, sisters are doing it for themselves!

HOW TO RIDE THE `PATABIKE

- Make sure, the wheel is powered on and sending intrinsic data odour to the host machine!
- Several LEDs will indicate preparation processes for a real-bootstrap!
- Enter the mollusc-mood style!
- Press keys to enter FULLSCREEN!
- Double-Check the Reality Engine!
- Scratch a bit forward backward, take a side-step, get tentative vertigo-motion!
- Reflect your playing style!
- Elude spatial sound obstacles!
- Configure volume && tactility!
- Enter luddite mode! enjoy JEU, jouissance!

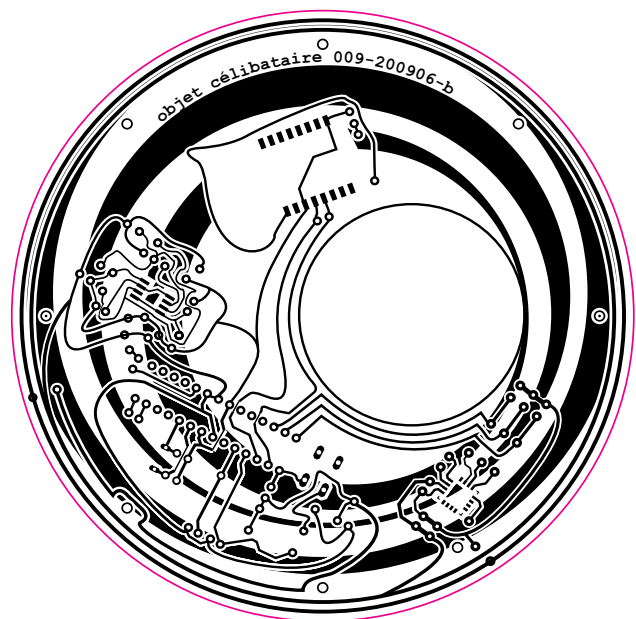

Picture 1.3
`Pataboard Layout



LUDIC-WHEEL - REALITY ENGINE DEVICE - OBJÉT CELIBATAIRE - PLAYING DADA-FUNK

Objet de jeu, de vie et d'art

The new bachelor machines, goApe chindogus are crafty self-etched circuit boards made of beautiful stylish black, specially etched circuit board material and decorative, electricity- and signal- conducting copper. The 'patastyled circuit boards aesthetic contains elements of a détournement bohemian artisanship. As bijoux they are self-sufficient, yet they are also sound-playing performance hammers, in other words, new bachelor machines.



Picture 1.4
Go-Ape Chindogus

In "the logics of the imaginative" Roger Caillois (1973) suggests the mollusc as soft conception model. The mollusc mood styled smooth new objets célibataires trigger electronic and 'pataphysic poetic glitches. Here glitch designed means that the processing drawings for the printed circuits boards are curved, twisted, twirled and spiraled, which is chique but abandoned in standard circuit board design, exactly because of possible electronic errors, called glitches for short. The spiral was not only the badge of Boris Vian, also on stage in Projex Pere Ubu concerts and at Oulipo meetings, it is also the PC layout for the Ludic Societies new bachelor objects. The nouvelle société ludique is identified by the tin-plated circuit bent monowheel object. If put on stage, it activates the Real Game and hands it over to each of us - the Real Players!

PERFORMANCE

Picture 1.5
Marguerite Charmant
LS Performance / Sao Paulo 2006

The mise en scène of these play objects in life defines the line of ludics as a process of inquiry, as a game, a discipline based on arts real play and scholarship.

CONTACT

<http://www.ludic-society.net>
<http://ludic.priv.at/ludicwheel>

margarete.jahrmann@hgkz.ch
Margarete Jahrmann
Breitensteinstrasse 31
8037 Zurich
Switzerland / Europe



'Pataboards have been developed in several Ludic Society Ouvroirs, so called Ludic-Society Chapters located at LSVc (Vienna), LSSc (Spain), LSRC (Rotterdam) and LSZC (Zurich).

Special Thanks to: www.konsum.net